



ARB® UTILITY MANAGEMENT SYSTEMS™ WATER | ELECTRIC | GAS

TRICON®/E/E2/E3 Transmitter Installation and Maintenance Guide



TRICON®/E/E2/E3 TRANSMITTER INSTALLATION AND MAINTENANCE GUIDE



ARB® UTILITY MANAGEMENT SYSTEMS™ WATER | ELECTRIC | GAS

TRICON®/E/E2/E3 Transmitter Installation and Maintenance Guide

This manual is an unpublished work and contains the trade secrets and confidential information of Neptune Technology Group Inc., which are not to be divulged to third parties and may not be reproduced or transmitted in whole or part, in any form or by any means, electronic or mechanical, for any purpose, without the express written permission of Neptune Technology Group Inc. All rights to designs or inventions disclosed herein, including the right to manufacture, are reserved to Neptune Technology Group Inc.

Neptune engages in ongoing research and development to improve and enhance its products. Therefore, Neptune reserves the right to change product or system specifications without notice.

Trademarks Used in this Manual

Neptune, TRICON, and Smartrol are registered trademark of Neptune Technology Group Inc.

Other brands or product names are the trademarks or registered trademarks of their respective holders.

Neptune Technology Group Inc.

1600 Alabama Highway 229
Tallahassee, AL 36078
USA

Tel: (800) 645-1892
Fax: (334) 283-7299

Neptune Technology Group (Canada) Ltd.

7275 West Credit Avenue
Mississauga, Ontario
L5N 5M9
Canada

Tel: (905) 858-4211
Fax: (905) 858-0428

Neptune Technology Group Inc.

Ejército Nacional No. 418
Piso 12, Desp. 1201-1202
Col. Chapultepec Morales
Delegación Miguel Hidalgo

11570 México, Distrito Federal
Tel: (525) 55203 5294 / (525) 55203 5708
Fax: (525) 55203 6503

1	OVERVIEW	
	Transmitter Styles.....	1-1
	Digital Pulse	1-1
	Analog 4-20mA.....	1-1
	Usage	1-1
	Contacting Technical Support.....	1-2
2	INSTALLING THE TRANSMITTER	
	Tools and Material.....	2-1
	Preparation	2-1
	Inspection and Storage	2-1
	Safety and Preliminary Checks	2-1
	Installation.....	2-2
	Wiring the Transmitter.....	2-2
	Testing the Wires	2-5
	Final Assembly	2-5
	Mounting the Transmitter	2-5
3	SPECIFICATIONS AND PERFORMANCE DATA	
	Environmental Conditions	3-1
	Electrical Specifications (TRICON E3 Models)	3-1
	Performance Data.....	3-3
4	MAINTENANCE	
	Troubleshooting.....	4-1

FIGURE	TITLE	PAGE
2.1	Elements of the Transmitter	2-2
2.2	Inserting Multi-Conductor Cable	2-3
2.3	Creating a Hook in the Wire	2-3
2.4	Connecting the Conductors to the Terminal Screws	2-3
2.5	TRICON/E/E2/E3 Wiring	2-4
2.6	Mounting the TRICON Transmitter	2-6

TABLE	TITLE	PAGE
2.1	TRICON/E/E2/E3 Wiring Codes	2-4
3.1	Pulse Outputs (over 0-70°C operating temp).....	3-1
3.2	4-20mA Model (over 0-50°C operating temp).....	3-2
3.3	HF and UP/DN Models (over 0-70°C operating temp).....	3-2
3.4	All Models Absolute Limits	3-3
3.5	T-10 Disc Meters	3-3
3.6	T-8 Disc Meters.....	3-4
3.7	Trident Turbine (TT) Meters.....	3-4
3.8	High Performance Turbine (HPT) Meters	3-5
3.9	Tru/Flo Compound Meters	3-5
3.10	4", 6", 8" and 10" HP Protectus III Turbine Elements Performance Specifications	3-6

CHAPTER 1 OVERVIEW

The TRICON® transmitter provides an electronic interface to Neptune water meters, enabling customers to monitor their water usage and control various processes based on that usage. The TRICON transmitter is available in two styles: Digital Pulse and Analog 4-20mA.

TRANSMITTER STYLES

Digital Pulse

The original Digital Pulse model is a 3-terminal transmitter which outputs electrical pulses at a rate corresponding to the rate of flow through the meter. It requires 12-24VDC operating power and is intended for use in applications requiring only a digital signal.

The TRICON/E2 and TRICON/E3 Digital Pulse models are 5-terminal transmitters which have the same features as the original Digital Pulse model plus two additional terminals (High Resolution Output and Count Direction) for connection to a high-speed, bi-directional counter. It requires 12-24VDC operating power, and is intended for use in applications requiring a high-resolution digital signal.

Analog 4-20mA

The Analog 4-20mA model is a 5-terminal transmitter which has the same features as the original Digital Pulse Model, plus two additional terminals for a 4-20mA output that is proportional to the rate of flow through the meter. It requires 24VDC operating power, and is intended for use in applications requiring analog and/or digital signals.

USAGE

All models are designed to be mounted between the meter maincase and a totalizing register, and they do not affect the normal operation of either the meter or the register. When used with a Smartrol® controller or other third-party instrumentation equipment, both models allow monitoring and/or controlling complex metering systems.

The Digital Pulse model TRICON/E transmitters are produced in only two styles: Disc and Turbine, for use with ALL Neptune disc meters or ALL Neptune turbine meters, respectively. The Analog 4-20mA model TRICON/E transmitters, however, are manufactured specifically for the size and type of meter with which they are to be used. For this reason, special care should be taken to ensure that you have the proper Analog 4-20mA model TRICON/E required for your application. Contact Neptune for technical assistance, if necessary.

CONTACTING TECHNICAL SUPPORT

If you encounter any problems with the installation or operation of your TRICON, please call Neptune at (334) 283-6555 and ask to speak with an Applications Engineer.

CHAPTER 2 INSTALLING THE TRANSMITTER

This chapter is designed to take you through the installation process for the TRICON transmitter.

TOOLS AND MATERIALS

The following equipment is required for the installation:

- medium, flat-head screwdriver
- wire stripper
- hammer
- small (1/8") diameter punch, or similar tool
- multi-conductor, solid, #22 AWG, copper cable
- Dow Corning® #4, or equivalent compound (optional)

PREPARATION

Be sure to review the following sections before beginning the installation.

Inspection and Storage

Remove the assembly parts from the parts bag and inspect them for any damage. The transmitter arrives partially assembled, with the terminal cover and mounting ring being the only separate parts.

Once the inspection is complete, store the cartons in a clean, dry environment. The temperature should remain between -40° and 185°F (-40° and 85°C).

Safety and Preliminary Checks

Always follow your local electrical and safety codes, and observe the following guidelines for running wire between your TRICON/E transmitter and the receiving device.

- Avoid installing your TRICON/E instrumentation wiring near sources of electrical noise, such as:
 - contactors, motor starters, and relays
 - radio transmitters and antennas
 - high-voltage power wiring and transformers

- Whenever possible, separate your instrumentation wiring from other wiring by using a separate metal conduit or metal wire tray.
- Use the minimum length of cable required for the installation and cut off any excess. Do not coil excess wire.



For longer runs (1,000' maximum) use #22 AWG shielded twisted pair cable for signal connections, and tie the shield to ground at the receiving device, not at the TRICON/E transmitter.

- When forced to cross other wiring, cross at right angles to minimize noise coupling between wiring.
- Use a dedicated power source, such as a separate circuit breaker or isolation transformer, for all instrumentation equipment to reduce the effects of electrical noise from other equipment on the line.
- Ensure proper earth ground is available and installed in compliance with local electrical codes.

INSTALLATION

Wiring the Transmitter

Follow this procedure to wire the transmitter.

- 1 Locate the terminal cover and remove the cover screw.
- 2 Lift the terminal cover from the transmitter.

Refer to Figure 2.1.

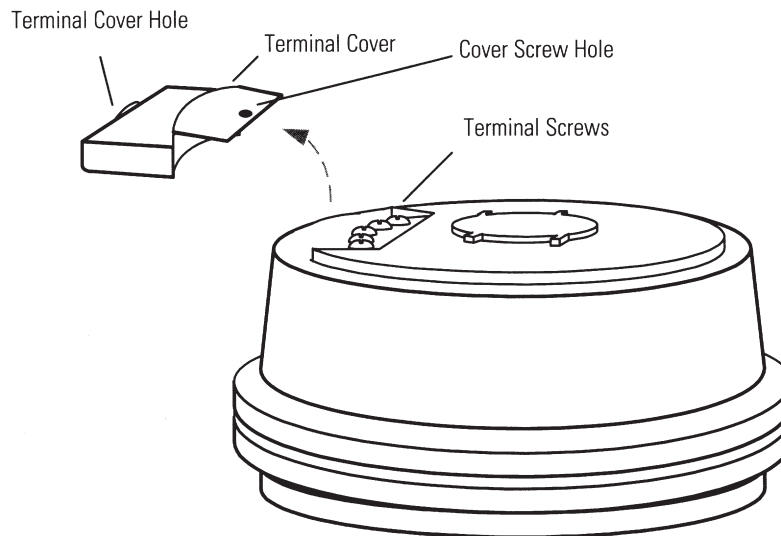

Figure 2.1 Elements of the Transmitter

- 3 Insert the end of the multi-conductor cable through the hole in the terminal cover as shown in Figure 2.2.

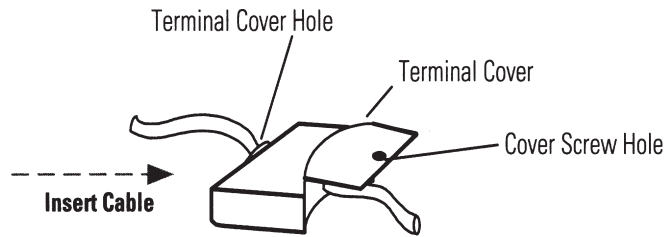

Figure 2.2 Inserting Multi-Conductor Cable

Move the cover far enough down the cable to allow you to work with the end that you just inserted.

- 4 Strip the outer covering of the cable back approximately 1-1/2" from the inserted end.
- 5 Separate the individual conductors and strip the insulation back approximately 1/2" from the end of each conductor.
- 6 Using the rounded shaft of the screwdriver, form a hook in the end of each bare copper wire. (See Figure 2.3.)

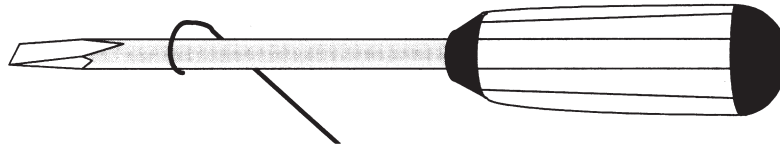

Figure 2.3 Creating a Hook in the Wire

- 7 Loosen the terminal screws, as shown in Figure 2.4.

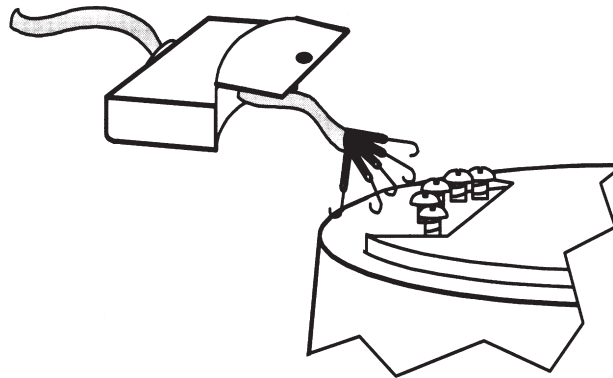

Figure 2.4 Connecting the Conductors to the Terminal Screws

- 8 Position the wire hook of each conductor under the proper terminal screw according to the appropriate wiring diagram.

Refer to Figure 2.5 and Table 2.1 for the wiring diagram.

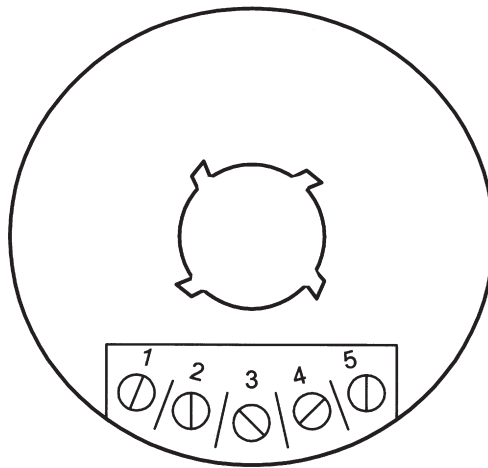

Figure 2.5 TRICON/E/E2/E3 Wiring

Table 2.1 TRICON E/E2/E3 Wiring Codes

PIN #	TRICON/E DIGITAL PULSE MODEL (PRIOR TO 1/96)	TRICON/E2 & E3 DIGITAL PULSE MODEL (AFTER 1/96)	TRICON/E, E2 & TRICON/E3 4-20MA MODELS
1	No Connection	High-Resolution Output ²	4-20mA Source (+) ¹
2	No Connection	Count Direction ²	4-20mA Return (-)
3	12-24VDC Power In (+)	12-24VDC Power In	24VDC Power In (+)
4	Common Ground (- side)	Common Ground (- side)	Common Ground (- side)
5	Pulse Output	Pulse Output	Pulse Output

¹The (+) indicates conventional current exiting the TRICON.

²This connection is a contact closure to ground and requires DC power to be supplied through a pull-up resistor. Typical pull-up resistor values are 2K per 5 volts of the DC voltage.

- 9 Place each wire hook so that it runs in a clockwise direction around the screw terminal, with no insulation under the screw head.
- 10 Use the tip of the screwdriver to close the hooks around the terminal screws and tighten the screws until snug.



Take care not to overtighten the terminal screws when completing the wiring.

Testing the Wires

After wiring the transmitter, double-check to ensure it is wired correctly. Apply power to the TRICON transmitter and check the output signals as follows:

- At **No Flow** - there should be no pulses out of the digital output terminal, and a 4mA direct current should be present in the 4-20mA loop.
- At **1/2 Flow** - the pulse rate out of the digital output terminal should be 1/2 the maximum pulse rate, and a 12mA direct current should be present in the 4-20mA loop.
- At **Maximum Flow** - the pulse rate out of the digital output terminal should be equal to the maximum pulse rate, and a 20mA direct current should be present in the 4-20mA loop.

Final Assembly

Once testing is complete, the transmitter is ready for the final steps of the assembly process.

- 1 Shut off all power to the TRICON.
- 2 Place a generous amount of Dow Corning #4 on all exposed wire and terminals.
- 3 Fill the inside of the terminal cover with the moisture compound.
- 4 Slide the terminal cover in place over the terminal screws.
- 5 Fasten the terminal cover with the cover screw and tighten until snug.



Take care not to overtighten the cover screw when securing the terminal cover.

- 6 Snap the strain relief fitting over the cable and push it into place in the cable entry hole.
- 7 Wipe away any excess compound.

Mounting the Transmitter

Once the transmitter has been assembled, it is ready to be mounted. If you are installing a TRICON transmitter on a meter that does not already have a register mounted on it, skip to step 4. If the meter does have a register mounted, begin at step 1.

- 1 Position the small end of the punch on the center of the seal pin at the base of the register.
- 2 Using the hammer, drive the punch through the center of the seal pin. The head of the pin should shear off.
- 3 Twist the register approximately 1/4 turn counter-clockwise and remove it from the meter.

Refer to Figure 2.6 for assistance with the following steps.

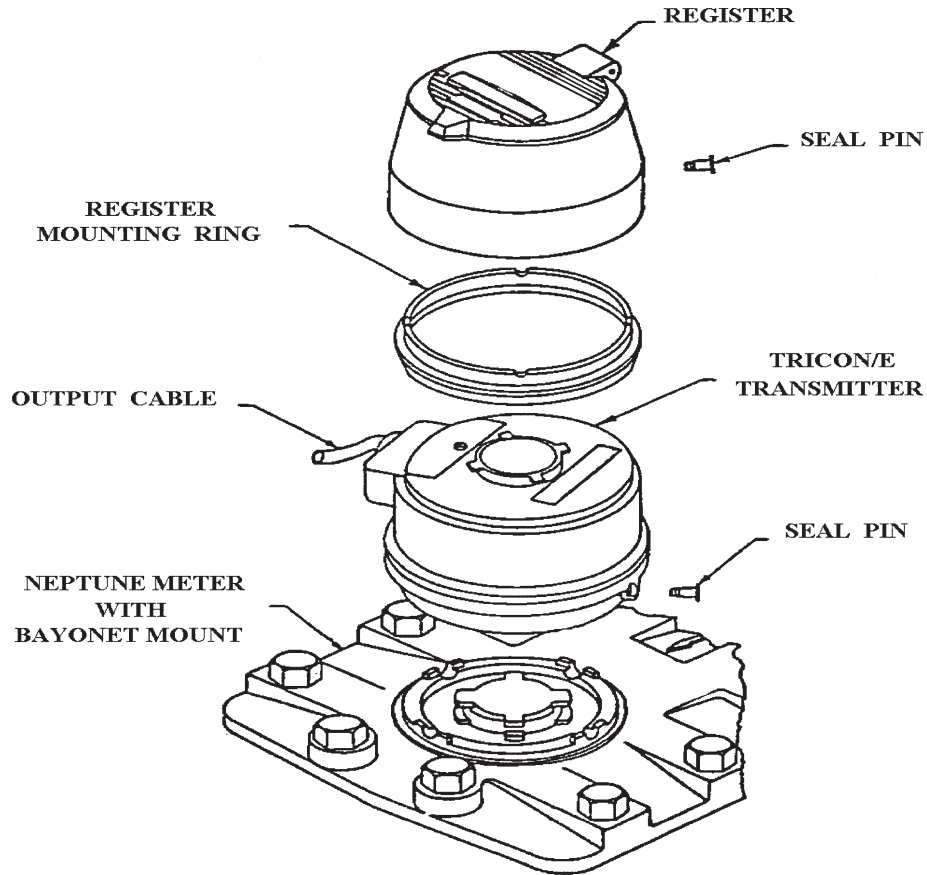

Figure 2.6 Mounting the TRICON Transmitter

- 4 Position the TRICON transmitter on the meter and twist it clockwise until it locks into place.
- 5 Place the register mounting ring on top of the TRICON transmitter with the four rounded grooves facing upward.
- 6 Align the notch in the base of the register mounting ring with the terminal cover of the TRICON and snap the ring into place.

When properly oriented, the register mounting ring should sit flush on top of the TRICON transmitter.

- 7 Position the register on top of the TRICON transmitter and register mounting ring, and twist it clockwise until it locks into place.
- 8 Drive the new seal pins into the register base and TRICON base to secure the installation and prevent tampering.

CHAPTER 3 SPECIFICATIONS AND PERFORMANCE DATA

This chapter will provide you with the electrical specifications and the performance data for the models of the TRICON transmitter.

ENVIRONMENTAL CONDITIONS

Operating Temperature	32° to 158°F (0° to 70°C)
Storage Temperature	-40° to 185°F (-40° to 85°C)
Operating Humidity	0 to 95% RH, non-condensing

ELECTRICAL SPECIFICATIONS (TRICON/E3 MODELS)

Table 3.1 Pulse Outputs (over 0-70°C operating temp)

PARAMETER	DESCRIPTION	MINIMUM	TYPICAL	MAXIMUM	UNITS
V _{ol}	Low Digital Pulse Output Voltage	—	0.4	—	V
V _{oh}	High Digital Pulse Output Voltage	8.5	V _{DCIN} -1.0V	12	V
I _{ol}	Current @ V _{ol}	—	-10	—	mA
I _{oh}	Current @ V _{oh}	—	+10	—	mA
t _r l-h ¹	Output Rise Time	—	—	2	μS
t _f h-l ¹	Output Fall Time	—	—	2	μS

¹Measured with R_L=2.4KΩ and C_L=50pF.

Table 3.2 4-20mA Model (over 0-50°C operating temp)

PARAMETER	DESCRIPTION	MINIMUM	TYPICAL	MAXIMUM	UNITS
Vcc	Power Supply Voltage	22.5	—	26.5	V
IS	Power Supply Current	20	—	80	mA
R _L	Loop Resistance	0	—	600	Ω
Gain	Scaling Accuracy	—	—	0.5	%FS
Zero	Offset Accuracy	—	—	0.2	%FS
Vol	Low Digital Pulse Output Voltage	—	0.4	—	V
Voh	High Digital Pulse Output Voltage	8.5	—	12	V
Iol	Current @ Vol	—	-10	—	mA
Ioh	Current @ Voh	—	10	—	mA
*t _r l-h ¹	Output Rise Time	—	—	2	μS
*t _f h-l	Output Fall Time	—	—	2	μS

¹Measured with R_L=2.4KΩ and C_L=50pF

Table 3.3 HF and UP/DN Models (over 0-70°C operating temp)

PARAMETER	DESCRIPTION	MINIMUM	TYPICAL	MAXIMUM	UNITS
Vcc	Power Supply Voltage	11.5	—	26.5	V
IS	Power Supply Current	20	—	50	mA
Vol	Low Digital Pulse Output Voltage	0	—	—	V
Voh	High Digital Pulse Output Voltage	—	24	26.5	V
Iol	Current @ Vol	-1.0	—	—	A
Ioh	Current @ Voh	—	0.04	+1.0 W/Voh	A
t _r l-h ¹	Output Rise Time	—	—	2	μS
t _f h-l	Output Fall Time	—	—	2	μS

¹Measured with R_L=2.4KΩ and C_L=50pF.

Table 3.4 All Models Absolute Limits¹

PARAMETER	DESCRIPTION	MINIMUM	MAXIMUM	UNITS
T (op)	Operating Temperature	0	85	°C
T (stg)	Storage Temperature	-40	85	°C
Vcc	Power Supply Voltage	-30	30	V
R _L	Output Load (pulse output)	1200	—	KΩ
I _{out}	Output Current (pulse output)	—	10	mA

¹These limits **cannot** be exceeded without possible damage.

PERFORMANCE DATA

Table 3.5 T-10 Disc Meters

METER SIZE (in)	MAXIMUM FLOW RATE (gpm)	MAXIMUM CONTINUOUS FLOW RATE (gpm)	MINIMUM FLOW RATE (gpm)	NUMBER OF PULSES PER GALLON ¹	PULSE OUTPUT @ MAXIMUM FLOW RATE (Hz) ¹	FLOW RANGE OF 4-20MA OUTPUT (gpm)
5/8	20	10	1/4	578.1	192.70	0–20
3/4	30	15	1/2	322.6	161.30	0–30
1	50	25	3/4	150.8	125.67	0–50
1 1/2	100	50	1 1/2	67.57	112.62	0–100
2	160	80	2	37.50	100.00	0–160

¹For the **High-Resolution Output** of TRICON/E2 transmitters, multiply these values by **36**, and for the TRICON/E3, multiply by **40**.

Table 3.6 T-8 Disc Meters

METER SIZE (in)	MAXIMUM FLOW RATE (gpm)	MAXIMUM CONTINUOUS FLOW RATE (gpm)	MINIMUM FLOW RATE (gpm)	NUMBER OF PULSES PER GALLON ¹	PULSE OUTPUT @ MAXIMUM FLOW RATE (Hz) ¹	FLOW RANGE OF 4-20mA OUTPUT (gpm)
5/8	20	10	1/4	473.60	157.87	0–24.41 ²
3/4	30	15	1/2	329.14	164.57	0–29.40
1	50	25	3/4	126.55	105.46	0–59.58 ²
1 1/2	100	50	1 1/2	47.86	79.77	0–141.18 ²
2	160	80	2	25.60	68.27	0–234.37 ²

¹For the **High-Resolution Output** of TRICON/E2 transmitter, multiply these values by **36**, and for the TRICON/E3, multiply by **40**.

²T-8 disc meters are no longer manufactured. Therefore, all TRICON/E transmitters manufactured for disc meters are the T-10 type. In most cases, the newer T-10 meter chamber is smaller than its corresponding T-8 meter chamber, which results in the TRICON/E having a theoretical “Flow Rate at 20mA Output” that is greater than the Maximum Flow Rate allowed for the meter. This means that the T-10 type TRICON/E running on a T-8 meter will never actually reach the 20mA output level during normal operation. The calculated flow rate required to produce a 20mA output is provided as a reference for use in calibrating the 4-20mA receiving instrument.

Table 3.7 Trident Turbine (TT) Meters

METER SIZE (in)	MAXIMUM CONTINUOUS FLOW RATE (gpm)	MINIMUM FLOW RATE (gpm)	NUMBER OF PULSES PER GALLON ¹	PULSE OUTPUT @ MAXIMUM FLOW RATE (Hz) ¹	FLOW RANGE OF 4-20mA OUTPUT (gpm)
2	200	3	4.608	15.36	0 – 200
3	450	5	2.89	21.68	0 – 450
4	1,000	10	1.59	26.50	0 – 1,000
6	2,000	20	0.464	15.47	0 – 2,000
8 (through S/N 31918014)	3,500	35	0.2493	14.54	0 – 3,500
8 (from S/N 31918274)	3,500	35	0.2253	13.14	0 – 3,873
10 (through S/N 31919282)	5,500	50	0.16	14.67	0 – 5,500
10 (from S/N 31919300)	5,500	50	0.1472	13.49	0 – 5,981

¹For the **High-Resolution Output** of the TRICON/E2 transmitters, multiply these values by **9** and for the TRICON/E3, multiply these values by **10**.

Table 3.8 High Performance Turbine (HPT) Meters

METER SIZE (in)	MAXIMUM CONTINUOUS FLOW RATE (gpm)	MINIMUM FLOW RATE (gpm)	NUMBER OF PULSES PER GALLON ¹	PULSE OUTPUT @ MAXIMUM FLOW RATE (Hz) ¹	FLOW RANGE OF 4-20MA OUTPUT (gpm)
1 1/2	160	4	6.095	16.25	0 – 160
2	200	4	6.095	20.32	0 – 200
3	450	5	11.20	84.00	0 – 450
4	1,200	10	7.556	151.10	0 – 1,200
6	2,500	20	0.7273	30.30	0 – 3,000
8	4,000	35	0.7556	50.37	0 – 4,000
10	6,500	50	0.7556	81.86	0 – 6,500
12	8,000	120	0.7556	100.75	0 – 8,000
16	13,500	200	0.07556	17.00	0 – 13,500
20	22,000	300	0.07556	27.71	0 – 22,000

¹For the **High-Resolution Output** of the TRICON/E2 transmitters, multiply these values by **9** and for the TRICON/E3, multiply these values by **10**.

Table 3.9 Compound Meters

Compound Meter ¹ Size and Type	Turbine Element	Disc Element
3" Tru/Flo	3" TT	5/8" T-10
4" Tru/Flo	4" TT	3/4" T-8
6" Tru/Flo	6" TT	1" T-8
2" HP Tru/Flo	2" HPT	5/8" T-10
4" Protectus III	4" TT	1" T-10
6" Protectus III	6" TT	1 1/2" T-10
8" Protectus III	8" TT	2" T-10
10" Protectus III	10" TT	2" T-10
4" HP Protectus III	²	1" T-10
6" HP Protectus III	²	1-1/2" T-10
8" HP Protectus III	²	2" T-10
10" HP Protectus III	²	2" T-10

¹For TRICON/E Performance Specifications of Compound Meters, refer to the specification information of each respective meter element.

²Refer to Table 3.10 for the performance specifications of the 4", 6", 8", and 10" HP Protectus III Turbine Elements.

Table 3.10 4", 6", 8", and 10" HP Protectus III Turbine Elements Performance Specifications²

METER SIZE (in)	MAXIMUM CONTINUOUS FLOW RATE (gpm)	NUMBER OF PULSES PER GALLON ¹	PULSE OUTPUT @ MAXIMUM FLOW RATE (Hz) ¹	FLOW RANGE OF 4-20MA OUTPUT (gpm)
4"	1,200	7.556	151.2	0 – 1200
6	2,500	0.7556	37.78	0 – 2.888
8	4,000	0.6095	40.63	0 – 4,959
10	6,500	0.5333	57.78	0 – 9,209

¹For the **High-Resolution Output** of the TRICON/E2 transmitters, multiply these values by **9** and for the TRICON/E3, multiply these values by **10**.

²Note: This table is based on mounting HPT TRICON/E3 on the same size HP Protectus III Turbine Element.

CHAPTER 4 MAINTENANCE

If you find that your TRICON system is not operating as expected when installed, use the following guidelines to try to determine the source of the problem.

TROUBLESHOOTING

If the TRICON appears to be operating, but electronic flow indication does not agree with mechanical register indication, try the following:

- Verify that the TRICON and register match the meter size and type.
If not, replace the TRICON and/or the register with the appropriate type to match the meter.
- Verify that the register turns smoothly when installed on the TRICON.
If not, replace the register or have it repaired to correct problems with excessive torque.
- Verify that the TRICON is wired and powered properly.
If not, correct the wiring/power problem.
- Verify compatibility and proper calibration of equipment to which the TRICON is connected.

Numerics

- 4-20mA 1-1
 - model, selecting 1-1
 - operating power 1-1
 - operating temperature 3-2
 - specifications 3-2

A

- absolute limits
 - electrical specifications 3-3
- assembly
 - of transmitter 2-5
 - illustrated 2-3

C

- Codes
 - wiring 2-4
- compound meters 3-5
- contacting
 - technical support 1-2
- cover screw 2-2
- cover screw hole
 - illustrated 2-2

D

- Digital Pulse 1-1
 - operating power
 - E 1-1
 - E2/E3 1-1
 - styles
 - Disc 1-2
 - Turbine 1-2

E

- E/E2/E3. *See* transmitter
- electrical specifications 3-1
 - 4-20mA 3-2
 - absolute limits 3-3
 - HF Models 3-2
 - Pulse Outputs 3-1
 - UP/DN Models 3-2
- environmental conditions 3-1
- equipment 2-1

H

- HF Models
 - operating temperature 3-2
 - specifications 3-2
- High Performance Turbine. *See* HPT Meters
- HPT Meters
 - performance data 3-5
- humidity, operating 3-1

I

- Inspecting
 - transmitter 2-1
- Installation
 - equipment needed 2-1
 - preliminary check 2-1
 - safety 2-1
 - wiring transmitter 2-2

M

- maintenance 4-1
- meters
 - compound 3-5
 - HPT 3-5
 - Neptune 1-1
 - T-10 Disc 3-3
 - T-8 Disc 3-4
 - TT 3-4
- models
 - 4-20mA 1-1
 - Digital Pulse 1-1
- moisture compound 2-5
- mounting
 - transmitter 2-5
 - illustrated 2-6

N

- Neptune meter 1-1

O

- Operating
 - conditions 3-1
 - humidity 3-1
 - temperature 3-1
- operating power
 - 4-20mA 1-1
 - Digital Pulse
 - E2/E3 1-1
 - digital pulse
 - E 1-1
- operating temperature
 - 4-20ma 3-2
 - HF Models 3-2
 - Pulse Outputs 3-1
 - UP/DN Models 3-2

P

- Performance
 - HPT Meters 3-5
 - T-8 Disc Meters 3-4
 - TT Meters 3-4
- performance data
 - T-10 Disc Meters 3-3
- pre-installation 2-1

- Pulse Outputs
 - operating temperature 3-1
 - specifications 3-1

R

- register mounting ring 2-5
 - illustrated 2-6

S

- safety 2-1
- seal pin 2-5
 - illustrated 2-6
- shipment
 - inspecting 2-1
- Specifications
 - 4-20mA 3-2
 - absolute limits 3-3
 - environmental 3-1
 - HF Models 3-2
 - Pulse Outputs 3-1
 - UP/ND Models 3-2
- Storage
 - temperature 2-1
- storage, temperature 3-1
- storing
 - transmitter 2-1
- strain relief fitting 2-5

T

- T-10 Disc Meters
 - performance data 3-3
- T-8 Disc Meters
 - performance data 3-4
- technical support 1-2
- temperature
 - operating 3-1
 - storage 3-1
- terminal cover 2-2
 - illustrated 2-2
- terminal cover hole
 - illustrated 2-2
- terminal screws 2-3
 - illustrated 2-3
- temperature
 - storage 2-1
- tools 2-1
- transmitter

- assembly 2-5
 - illustrated 2-6
- elements, illustrated 2-6
- inspecting 2-1
- maintenance 4-1
- mounting 2-5
 - illustrated 2-6
- storage 2-1
- storage temperature 2-1
- styles
 - 4-20mA 1-1
 - Digital Pulse 1-1
- testing wiring 2-5
- troubleshooting 4-1
- wiring 2-2
 - wiring codes 2-4
 - wiring diagram 2-4
- TRICON/E/E2/E3. *See* transmitter
- Trident Turbine. *See* TT Meters
- troubleshooting 4-1
- TT Meters
 - performance data 3-4
- Turbine style 1-2

U

- UP/DN Models
 - operating temperature 3-1
 - specifications 3-2

W

- Wiring
 - codes 2-4
 - diagram 2-4
 - testing 2-5
 - transmitter 2-2

Neptune Technology Group Inc.

1600 Alabama Highway 229
Tallahassee, AL 36078
USA

Tel: (800) 645-1892
Fax: (334) 283-7299

Neptune Technology Group (Canada) Ltd.

7275 West Credit Avenue
Mississauga, Ontario
L5N 5M9
Canada

Tel: (905) 858-4211
Fax: (905) 858-0428

Neptune Technology Group Inc.

Ejército Nacional No. 418
Piso 12, Desp. 1201-1202
Col. Chapultepec Morales
Delegación Miguel Hidalgo
11570 México, Distrito Federal
Tel: (525) 55203 5294 / (525) 55203 5708
Fax: (525) 55203 6503



NEPTUNE
TECHNOLOGY GROUP
Take Control.

neptunetg.com